

Multi-Cable Lock-Off Anchor

DESCRIPTION

There are two types of Multi-Cable Lock-Off Anchor configurations; a two-cable lock-off, and a three-cable lock-off. Both anchors are exclusively for use with ½” seven wire prestress cable and may not be used with any other types of cable or wire rope.

RECOMMENDATIONS FOR USE

1. Stacking Anchors:

- a. There are several unique design features of the anchor that permit the Multi-Cable Lock-Off Anchor to lock-off up to four or five post-tensioned cables:
 - The wide anchor slot will permit a single bundle to fit within the anchor.
 - The wedge cavities allow the use of off-the-shelf wedges.
 - The recessed wedge face allows the anchors to be stacked on top of each other, which is critical to locking-off all the cables in a bundle.
- b. The cables should align with the centerline of the wedge cavities, which is why the anchors are designed to be stacked on top of each other. It is assumed that several anchors will be required to lock-off all the cables in a single bundle.
- c. The sketch below illustrates this concept. Lock-Off Anchor 1 on the bottom is used to secure the second and fourth cables in the bundle (marked as 1 and 2). Lock-Off Anchor 2 on the top is used to secure the first, third, and fifth cables in the bundle (marked as 3, 4, and 5).

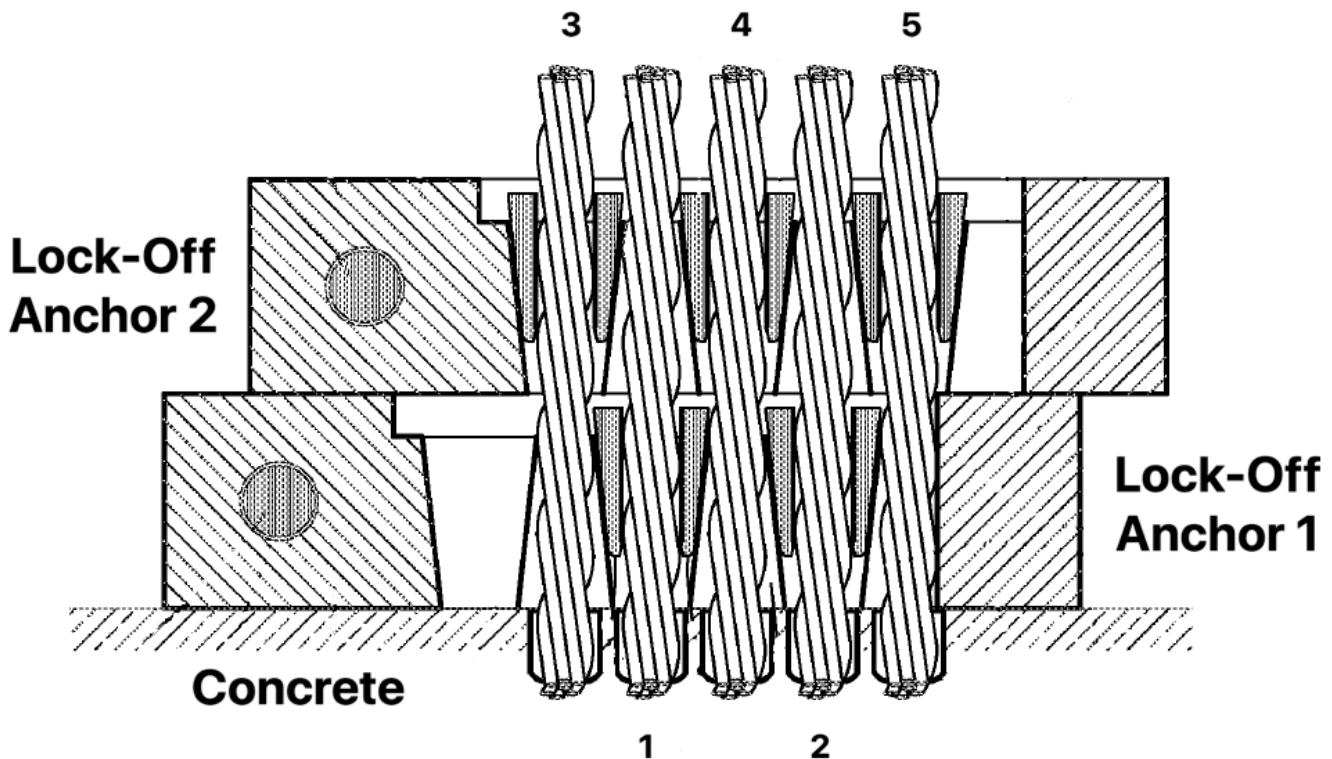

2. Cable and Wedge Cavity Alignment – Use of Backer Plates:

- a. There may be instances where the use of a backer plate spacer between the concrete substrate and the first anchor may be utilized in order to provide enough room for the cables to be spread SLIGHTLY.
- b. This should only be considered in those instances where MINIMAL room is needed in order to provide for a straighter alignment of the cable relative to the centerline of the Lock-Off Anchor wedge cavity.
- c. The thickness of the backer plate spacer should be at least $\frac{3}{4}$ " to 1" in thickness, and the dimensions of the plate should be equal to or greater than the dimensions of the Multi-Cable Lock-Off Anchors. The maximum thickness of the plate should not exceed 3".
- d. The sketch below illustrates a backer plate with a slot provided to install over the cable bundle. Note the absence of a recess in the face of the plate for the wedges, as it not necessary because it should only be installed between the concrete and the back of the first Lock-Off Anchor.

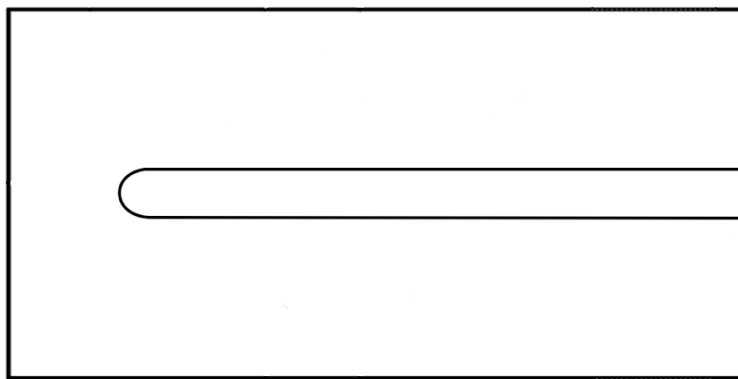

- e. The next sketch below illustrates how the backer plate may be used with a stack of Multi-Cable Lock-Off Anchors.

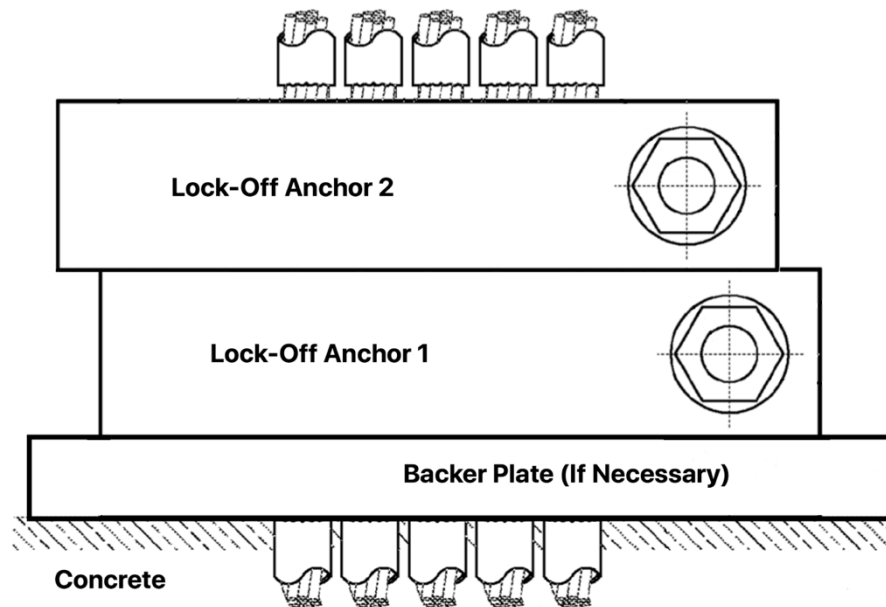

3. Wedge Orientation:

- a. It should be recognized that there are significant stressing loads transferred into the Lock-Off Anchor wedges during their use. As with any type of post-tensioned anchor, this force can make it extremely difficult to remove the wedges once they have been seated by the cable loads.
- b. Therefore, it is recommended that the wedges be installed on the top and bottom of the cables in the twelve o'clock and six o'clock positions. Wedges installed on the sides of the cables in the three o'clock and nine o'clock positions can be more difficult to remove.
- c. EXTREME CAUTION should be used in the removal of the wedges from the anchor after the cable stressing loads have been returned to the permanent tendon anchors, as this process can damage the cables and result in their failure.
- d. The sketch below illustrates both a proper and improper wedge orientation. The wedges on the left and right wedge cavities are correctly installed. The wedges in the center are improperly installed.

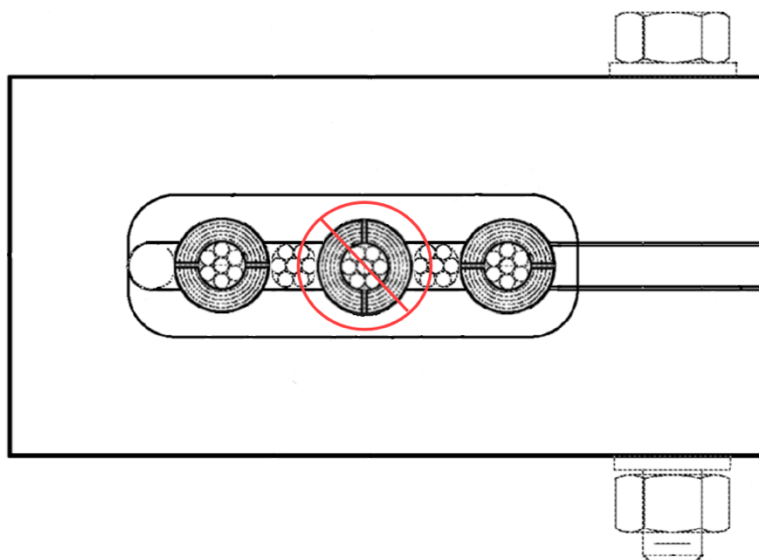

WARNING

1. The Multi-Cable Lock- Off Anchor is intended for use only as a temporary anchor for the repair of post-tensioned cables.
2. It can't be emphasized strongly enough that these anchors should be used only by those persons with substantial experience in post-tensioned cable repair using similar cable lock-off devices. It is the responsibility of the user to ensure that only adequately trained and properly supervised personnel use these devices.
3. The Multi-Cable Lock- Off Anchor should only be used with wedges provided by the manufacturer. The use of any other wedge can result in the catastrophic failure of the anchor.
4. Use only A490 or Grade 8 high-strength bolts with these anchors. The use of lower strength bolts may permit the anchors to spread under load, which may allow the cables to release from the anchor.
5. The Multi-Cable Lock-Off Anchors should NEVER be used without both the anchor slot insert (which is temporarily removed during installation) and the correct A490 or Grade 8 high-strength bolts.
6. The Multi-Cable Lock-Off Anchor should be inspected BEFORE EACH USE for signs of damage and/or fatigue. Discard any anchor device if there is ANY QUESTION of the integrity or suitability of the anchor. DO NOT USE any Multi-Cable Lock-Off Anchor if the integrity of the device is in question.

LIABILITY DISCLAIMER

It should be recognized that these lock-off anchors are intended for use in the repair of post-tensioned cables, and these activities are by nature, associated with a high level of risk. These risks include but are not limited to serious physical injury, disability and/or death, and significant property damage. It is strongly recommended that the anchors be used only by those persons with a suitable level of training and experience in post-tensioned cable repair with similar devices. It is the responsibility of the user to inspect the concrete substrate at EVERY LOCATION of intended use of the Multi-Cable Lock-Off Anchor PRIOR to installation of the device, and to determine that the concrete substrate is sufficiently reinforced, and of adequate strength and integrity. It is the sole responsibility of the user to determine if the Multi-Cable Lock-Off Anchor is appropriate for use in each situation, as there may be instances where this device cannot be used.